



National Order of the Arrow Committee

To: Contingent Leaders

On behalf of the National Order of the Arrow Committee, many grateful parents, and a whole bunch of kids (who may forget to say so), THANK YOU for leading a contingent from your lodge to the National Order of the Arrow Conference this summer at Michigan State University!! I hope this guide helps prepare you and your lodge for a fun and most rewarding Centennial NOAC.

Many, many Arrowmen from across the country have been working for months to prepare for our largest and most meaningful conference, ever - the crowning moment in the year-long Celebration of our 100th Anniversary.

As you and your youth develop your plans to maximize the benefit to each Arrowman attending, we hope that this guidebook, the NOAC website (event.oa-bsa.org), and the Lodge Ledger will continue to supply you with the most up to date and accurate information on which you can organize your experience.

The theme that our youth have chosen this year, "It Starts with Us" is a message to our guests that each of us has the power to begin something bigger than ourselves; create a new tomorrow by action TODAY; has the capacity to learn from and teach others, and to spread the enthusiasm brought on through service when they return home – fired up and committed to the ideals passed down from our founders.

We are thrilled with the exciting programs our youth leaders have designed for this NOAC, and we hope that you will remember to bring your lodge crate full of kiln-dried wood to burn in the centennial fire, your lodge crate lid painted with a favorite lodge scene, and the history of your OA lodge, which will all be on display. Each lodge that brings lodge wood to burn and participates in the dedication fire ceremony will receive a vial of ashes from the centennial fire.

Nationally, we have made our lists and are checking them twice, but we also realize that no one is more important in the NOAC life of our Scouts than YOU. As a contingent leader of my own lodge in past years, I know what you are going through now and what you will be asking yourself to do when the boots hit the ground in Michigan. Your leadership and attention to your Arrowmen will make more of a difference in the legacy we all leave, than all the planning and prep work we have done nationally.

You really will be the ones who make the difference at this NOAC; and I thank you for taking on the task of translating the great work, exciting program, and unique opportunities which we will offer to the youth, by ensuring that they attend, participate, and get home happily and safely to their Momma.

With a grateful heart for what you are doing, I remain devotedly,

Yours in Service,

National Chairman

RAY CAPP
Chairman

ALEXANDER C. CALL
National Chief-2014

DONALD J. STEPHENS
National Vice Chief-2014

CLYDE M. MAYER
OA Director

MATTHEW W. DUKEMAN
OA Specialist

BRADLEY E. HADDOCK
*Immediate Past Chairman
Partnerships*

EDWARD A. PEASE
*Past Chairman
Council Relations*

CARL M. MARCHETTI
*Past Chairman
Centennial Campaign*

CHRISTOPHER A. GROVE
*Arrowhead of Service
Award Recipient*

CRAIG B. SALAZAR
*Vice Chairman
Communications & Technology*

N. ANTHONY STEINHARDT, III
*Vice Chairman
Development*

GLENN T. AULT
*Vice Chairman
Financial Operations*

MICHAEL G. HOFFMAN
*Vice Chairman
National Events and
100th Anniversary*

CHRISTOPHER A. GROVE
*Vice Chairman
Outdoor Adventures*

MICHAEL L. THOMPSON
*Vice Chairman
Recognition, Awards
History and Preservation*

STEVEN D. BRADLEY
*Vice Chairman
Region & Section Operations*

DAVID W. GARRETT
*Vice Chairman
Training*

JEFFERY Q. JONASEN
*Vice Chairman
Unit, Chapter, and Lodge Support*

CLINT TAKESHITA
*Vice Chairman
Membership & Retention*

SCOTT W. BECKETT
*Vice Chairman
Special Projects*

HECTOR A. (TICO) PEREZ
*Vice Chairman
Youth Protection*

TABLE OF CONTENTS

I.	2015 National Conference.....	2
	Dates and Location	
	Attendance	
	Conference Fee	
	Council Contingent Reservations	
	NOAC Promotion Patch	
	Lodge Patches	
	Cancellation and Refund Policy	
	Lodge Key 3 Recognition	
II.	Conference Site.....	3
	East Lansing	
	Michigan State University	
	Campus Highlights	
III.	National Conference Organization.....	4
	National OA Committee	
	NOAC Conference Staff	
	NOAC Contingent Volunteers Needed	
IV.	Administration.....	7
	Conference Clinic and Medical Information	
	Special Situations/Special Needs	
	Leadership Policy	
	Insurance Coverage	
	Emergency Procedures Enroute	
	Arrival and Departure Procedures	
	Keep the University Grounds Clean	
	Policy on Smoking, Alcohol and Drugs	
	Child Abuse	
	Youth Protection Training and Background Checks Mandatory	
V.	SPARK: 2015 National OA Conference Wide Game.....	13
	Touchpoints	
	App & Website	
VI.	General Information.....	14
	Tour and Activity Plan	
	Vehicle Insurance and Drivers	
	Travel Responsibilities	
	In Case of Emergency	
	MSU Emergency Phone Numbers	
	If Separated from the Unit	
	Social Media @ NOAC	
	NOAC Website	
VII.	Services and Facilities.....	16
	Postal Service	
	Advance Shipments of Exhibits & Equipment	
	Airport Transportation Shuttle, Amtrak Shuttle, Campus Shuttle	
	Trading Post	
	Room Keys and Conference Cards	
	Lost and Found	
VIII.	Uniforms and Equipment.....	17
	NOAC Dress Code	
	Recommended Personal Equipment	
	Bicycles	
	Towels and Bedding at MSU	
	Contingent Equipment	
IX.	Giant Lodge Flap Specs.....	19
X.	Code of Conduct.....	20

I. 2015 NATIONAL ORDER OF THE ARROW CONFERENCE

NATIONAL OA CONFERENCE

The National Order of the Arrow Conference is Scouting's second-largest national program event. The reason for its growing popularity can be attributed to the fact that it is planned and carried out by Arrowmen. Youth involvement ensures that the conference will be exciting, relevant, and non-stop fun.

As you promote the conference to your membership and plan the details for your council's involvement in conference activities, keep in mind the many benefits that are likely to accrue for your lodge and its members. Participants will return home with:

- A deeper understanding of the Scout Oath, Scout Law, Order of the Arrow Obligation, and what it means to "live" these words in one's daily life.
- A renewed spirit, pride, and enthusiasm for Scouting and the Order of the Arrow.
- Ideas their lodge can use to better serve Scouting in their home unit and council.
- New program ideas, knowledge, and skills to improve lodge and chapter operations.
- Enhanced leadership skills and a better understanding of how to carry out the work of the lodge.
- The latest information on outdoor and high-adventure programming, including how to successfully promote Boy Scout camping.
- New friendships with fellow Arrowmen from throughout the nation.
- Memories to last a lifetime!

DATES AND LOCATION

The 2015 National Order of the Arrow Conference will begin with dinner on Monday, August 3 and end after breakfast on Saturday, August 8, 2015, at Michigan State University in East Lansing. All council contingents will be able to select an arrival time for Monday, August 3, through the NOAC Registration Portal at <https://registration.oa-bsa.org>, starting April 1, 2015.

(The conference will not include an early arrival day.)

ATTENDANCE

All Arrowmen who are registered members of the Boy Scouts of America and have their council's approval, are eligible to participate in the 2015 national conference.

All participants must register as a member of a council contingent or be a member of the conference staff.

CONFERENCE FEE

The conference fee is \$475.00 for youth and adult members who pay their total conference fee by May 31, 2015 (postmark date). Fees paid after May 31, 2015 will be \$550.00 for youth and adult members. All late fees must be received by the OA director no later than June 30, 2015. The fee includes five night's housing, five full days of program and training, 14 meals, program and support materials, registration materials, insurance, and recognition items during the six-day conference. The fee is payable in the following manner:

COUNCIL CONTINGENT RESERVATIONS

On October 1, 2014, a ratio of 3-youth reservations to every 1-adult reservation (3:1) was established for the 2015 NOAC; however councils are expected to provide every opportunity for Arrowmen under the age of 21 to attend NOAC. Adult participation should be approved on the basis of need to provide responsible leadership supervision for the council contingent (**at least one adult for every 15 youth attending**); and all contingents must maintain at least two-deep adult leadership traveling to and from and during the conference.

To secure the youth and adult spaces desired, each council must complete the on-line Council Contingent Reservation. Your council will be billed for the nonrefundable deposit of \$100.00 per-participant. No individual reservations will be accepted. **All Council Contingent Reservations must be processed through the National online payment system: Website: <https://registration.oa-bsa.org>. (NOAC Registration Portal)**

Councils will be billed the remainder of each participant's fee in two installments: \$200 in February and \$175 in May of 2015.

Encourage adult Arrowmen in your council to establish a special fund to help youth members attend and

share in the conference spirit. Your council and Scouting will benefit for years to come.

NOAC PROMOTION PATCH

A specially designed 2015 NOAC promotion patch will be mailed to contingent leaders after their participant reservation deposits are received in the national office. **Participants are encouraged to wear the patch on their Scout uniform (Jamboree patch location) to help promote the conference and may purchase extras to sew on their uniforms. A conference patch will also be sold at NOAC and can be pre-ordered by going to the OA Trading Post Portal online.**

LODGE PATCHES FOR THE 2015 NOAC

For lodge patches, a third party letter of permission is not required from Michigan State University if the words "MSU" or "Michigan State University" are used to identify the location of the 2015 NOAC event. Any other use of the Michigan State University trademark logo or Spartan logo is not permitted. The words "MSU" and "Michigan State University" should appear in all capital letters. No years or numbers may be attached to the words "MSU" or MICHIGAN STATE UNIVERSITY." If a year is to be included to identify the NOAC event, it should clearly be associated with NOAC and separated from the words "MSU" or "MICHIGAN STATE UNIVERSITY." **Use of the university mascot "Sparty" will not be approved.**

CANCELLATION AND REFUND POLICY

The \$100.00 per-person deposit is transferable to a substitute participant (**youth or adult**) within the same council on a one-for-one basis but it is nonrefundable, and may not be applied to the balance due for another person. All requests for cancellation made in writing to the OA director by June 30, 2015 will receive a full refund of all fees minus their deposit amount of \$100.00. Participants canceling their reservation after June 30, 2015 will forfeit their entire conference fee. (The OA director will consider refunds for medical reasons after June 30, 2015.)

LODGE KEY 3 RECOGNITION

The Lodge Key 3 will receive an attractive golf shirt with the conference logo on the front for attending the 2015 NOAC. (The Lodge Key 3 includes the lodge chief, lodge adviser, and lodge staff adviser or Scout executive; and all three members must attend to receive this special recognition.) Golf shirts can be picked-up at the NOAC trading post location on the university campus.

II. CONFERENCE SITE

East Lansing, Michigan

(MSU) and this summer's NOAC. East Lansing lies about 90-miles west-northwest of Detroit, and adjacent to Lansing, MI. The town was founded around 1847, the same year Lansing was established as the state capital. MSU was founded eight years later, and soon became the cornerstone of the town. It wasn't until 60 years later, in 1907, that East Lansing was officially incorporated as a city. Initially, it was to be called College Park. Today, East Lansing has grown into a classic university town with a population of around 48,500. East Lansing is located in south-central Michigan, and is accessible via numerous transportation avenues. The city is served by three interstates, I-96, I-69, and I-496, and a US Highway 127. Amtrak and Greyhound rail and bus lines stop at the East Lansing Amtrak depot, in walking distance of MSU. The Capital Region International Airport in Lansing hosts flights on Sun Country Airlines, some

East Lansing is the home to Michigan State University Delta Connections, and United Express. However, many travelers may find it more convenient to fly into either the Gerald R. Ford International Airport in Grand Rapids or the Detroit Metropolitan Wayne County Airport near Detroit. The Capital Area Transportation Authority (CATA) provides public bus transportation throughout East Lansing, Lansing, and the surrounding area.

Michigan State University

MSU was founded in 1855 as the forerunner of the land-grant universities supported by the Morrill Land-Grant Act. One of the nation's leading research institutions, Michigan State instructs nearly 48,000 students. The MSU Spartans participate in Division 1 athletics as a member of the Big Ten Conference. Their mascot is Sparty the Spartan and their colors are green and white.

Campus Highlights:

Beaumont Tower

The Beaumont Tower, built in 1928, is one of the most recognizable landmarks on campus. It was intended to

be a gathering place for student groups and a center of campus life. In addition to being a working 104-foot-tall clock tower, it serves as the meeting place for the board of the MSU Tower Guard, the oldest student organization on campus. It marks the location of College Hall, the first building in America specifically built to instruct students on scientific agriculture.

W. J. Beal Botanical Garden

The W. J. Beal Botanical Garden, named after its creator, Professor William J. Beal, was started in 1872, and is claimed to be the oldest continually-maintained university botanical garden in the US. It spans 5-acres and is open to the public free of charge year round. Over 5,000 species of plants are displayed in the Garden.

Spartan Stadium

Spartan Stadium home field of the MSU Spartans, opened in 1923. It holds 75,005 guests, making it the

sixth largest stadium in the Big Ten. The stadium boasts a natural grass field. In addition to football games, the Rolling Stones have performed in the stadium and an ice rink was built on the field for a hockey game against MSU rival, the University of Michigan.

Breslin Student Events Center

The Breslin Center serves as a multipurpose arena at MSU. It is home to the Spartan men's and women's basketball teams and seats 15,138 guests. Other events hosted at the Breslin Center include the Michigan State Bar examination, commencements, monster truck rallies, and large concerts. Some of the performers who've visited the center include Aerosmith, Kenny Chesney, Dave Matthews, Bob Dylan and Kanye West.

III. NATIONAL CONFERENCE ORGANIZATION

NATIONAL OA COMMITTEE

The National Order of the Arrow Committee, led by Chairman Ray Capp from Nashville, Tennessee, will host and provide overall guidance and leadership to the 2015 NOAC.

Veteran Arrowmen from around the nation make up the national committee and bring to the NOAC not only extensive Order of the Arrow and Scouting experience, but years of experience in staging and administering national events.

Michael Hoffman of Scottsdale, Arizona has been appointed conference chairman and will be assisted by the following deputies: Glenn Ault, Scott Beckett, Jack Butler, Andy Chapman, Randy Cline, Carey Mignerey and Clint Takeshita. National Chief Alex Call from Corpus Christi, Texas and National Vice Chief Donald Stephens from Scranton, Pennsylvania will provide leadership to our Conference Vice Chiefs (CVCs). Clyde Mayer, National OA Director, will be the NOAC staff adviser.

The following veteran Scouters, each with extensive NOAC experience, have been appointed to serve as LEAD ADVISERS to one of the functioning committees for the 2015 national conference:

Activities and Recreation

Mike Bliss

Klamath Falls, Oregon

Email: mikebliss@charter.net

Responsible for staging a variety of activities, including: athletic competition, recreation activities, movies, hot air balloons, Demmer Shooting Sports Center, OA Warrior, and religious services.

Administrative Services

Chris Grove

Troy, Ohio

Email: cgrove@woh.rr.com

The support arm of the conference, providing for a variety of services that make the conference operate smoothly: registration, housing, food service, equipment and material procurement, transportation, security, health and safety, storage, etc.

American Indian Activities

Ron Bell

Miami, Florida

Email: Ironbell@bellsouth.net

Responsible for conducting the many and varied American Indian programs, including pageants, dance, singing, and regalia competitions, and the American Indian Show.

Centennial Festival

Donald J. Cunningham

New York, New York

Email: DonaldJCunningham@alumni.upenn.edu

Responsible for developing and providing leadership to all events & activities surrounding the Order's centennial at the conference, which include the following: Legacy Display, Centennial Rededication & Centennial Fire, Centennial Gala, Centurion Reception, & Centennial Festival.

Communications

Tony Fiori

New York, New York

Email: afiori@gmail.com

Responsible for the various media outlets at NOAC, including the newspaper, website, social media, hometown blogs, information booths, and national event promotions.

Concierge

Frank Harper

Newnan, Georgia

Email: fourlittleharpers@yahoo.com

Responsible for all special guest and VIP's attending the conference. This committee will also serve as the liaison between the council contingent leaders and the OA and university staffs.

Endowment

Jason Hood

Memphis, Tennessee

Email: Jason.Hood@yahoo.com

Responsible for furthering the efforts of the Order of the Arrow Endowment program at NOAC, through recognizing donors, conducting the program at the Goodman Society Luncheon, and other promotional efforts.

Financial Services

Craig Davis

Austin, Texas

Email: mail@craigdavis.net

Responsible for oversight of daily financial and business operations of the conference. Directly responsible to the conference chairman and OA director for fiscal operations.

Foreman Corps

Alyx Parker

Savoy, Illinois

Email: alyxparker@yahoo.com

Responsible for assisting lodge contingents during arrival and departure, pre-conference mobilization of all program areas, providing manpower support during the conference, and for disassembling program areas at the end of the conference for shipment off university property.

Inductions and Ceremonial Events (ICE)

John Rotruck

Gaithersburg, Maryland

Email: johnrotruck96@gmail.com

Responsible for helping lodges improve the quality of the full spectrum of their OA inductions, from conducting unit elections to the Vigil Honor, via classroom sessions and live evaluation of ceremonial teams.

NESA@NOAC

Steve Silbiger

Los Angeles, California

Email: vigilss@sbcglobal.net

Responsible for all NESA events and activities at the conference, which include NESA sponsored show entertainment, Gathering of Eagles, and other related exhibits and activities.

Outdoor Adventures

Nick Digirolamo

Tampa, Florida

Email: nick.digirolamo@raymondjames.com

Responsible for all high adventure related activities, including the Experience (EXPO), The HUB, OA Extreme, STEM, Arrowman Conservation School, high adventure training, etc.

Region Chiefs

Steve Bradley

Riverside, California

Email: sbrad8854@aol.com

Responsible for OA contingent arrival orientations, experiences and activities at the conference. This committee will also conduct the Thursday night Grand Hodag. On Friday, each region will also have an exhibit at the Centennial Festival.

Registration

Tim Terry

Lexington, Kentucky

Email: registrar@registration.oa-bsa.org

Responsible for working with council contingents and staff during the pre-event registration process and on-site check-in.

Shows

Max Sasseen
Lawton, Oklahoma

Email: max@sasseenrealtgroup.com

Responsible for the development, production, and staging of the Opening Show, National Recognition Show, 100th Anniversary Show, Theme Show, and supporting the American Indian and NESAs Shows at the conference.

Special Events

Tony Steinhart
Indianapolis, Indiana

Email: tsteinhardt@ratioarchitects.com

Responsible for all special events and activities, receptions, Very Important Arrowmen (VIA) luncheons, Distinguished Service Award and Red Arrow reception and dinner, professional Scouter breakfast, meeting with national officers and committeemen, OA museum, and the NOAC band and chorus.

Technology

Craig Salazar
Franklin, Tennessee

Email: craig@salazar-family.com

Responsible for providing all the necessary technology support for all functioning conference committees, administration, and program.

Trading Post

Kay Trick
New Berlin, Pennsylvania

Email: ktrick@ptd.net

Responsible for the successful operation of the "NOAC", Endowment, American Indian, and satellite trading posts at the conference.

Training

David Garrett
Franklin, Tennessee

Email: david@cpgarrettlaw.com

Responsible for planning, developing and conducting all training programs and educational opportunities for both youth and adult Arrowmen; this includes the National Conference of Chiefs (NCO) session at the conference.

NOAC Conference Staff

A national Order of the Arrow conference could not function effectively without the dedicated service of those Arrowmen who volunteer to work with one of the conference committees. These Arrowmen are referred to as "conference staff."

Members of the NOAC conference staff pay their own way to the conference and work in a support role to help make the national conference program a successful and enjoyable experience for all Arrowmen.

NOAC Contingent Volunteers NEEDED

Due to the increased number of conference guests; the NOAC staff needs assistance in order to provide the best possible experience for youth Arrowmen attending the conference. As a result, we are looking for adult leaders and advisers, who are attending NOAC, to volunteer in a temporary staff capacity for a few hours, to help facilitate conference events and activities. During the individual registration process, adult conference participants will be given the opportunity to volunteer for a provisional staff assignment. They will also have a chance to indicate if they have any related skills, experience or certifications in regards to conference activities. Anyone who volunteers to serve as a provisional staff member will still be able to enjoy a full NOAC experience, while helping to ensure every youth Arrowman has an amazing week. Encourage adults in your contingent to help us fulfill this need.

IV. ADMINISTRATION

Conference Clinic

NOAC participants will have a full-time health care staff available at the conference, with first aid capabilities. The conference clinic will be located in Butterfield Hall, located within the Brody Complex, and will be open 24 hours each day of the conference. A satellite clinic will also be located in McDonel Hall.

Medical Requirements

Everyone attending the 2015 National Order of the Arrow Conference will be required to have completed and submitted a BSA Annual Health and Medical Record (Parts A, B and C) online prior to arrival at the conference. No other type of medical form will be accepted.

All BSA Annual Health and Medical Record forms for the 2015 NOAC must be submitted online by June 30, 2015. Arrangements will be made for any participant and staff substitutions after this date.

The medical examination must have been performed by a licensed practitioner after July 31, 2014.

Each person attending the 2015 NOAC will have to generate their individual bar coded Annual Health and Medical Record form for the conference. In order to create this form, participants and staff members will be required to enter their registration page through the NOAC Registration Portal at <https://registration.oa-bsa.org/>. Once this form has been filled out, they will need to take the form to their physician. Examinations conducted by licensed health care practitioners, other than physicians, will be recognized for BSA purposes in those states where such practitioners may perform physical examinations, within their legally prescribed scope of practice.

Upon completion of the examination, each participant and staff member will then enter their portal again and follow the instructions for uploading their medical form.

Anyone who was able to complete their medical form before the electronic system began will need to submit their form as well. Instructions for your submission process can be obtained by contacting **BSA Member Care at 1-972-580-2489, option "1", between the hours of 7 a.m. and 7 p.m. Central Time. No one will be expected to return to their practitioner's office for a second visit.**

Each youth and adult participant must provide a legible copy of the BSA Annual Health and Medical Record to their council service center for approval by the lodge's contingent leader.

Each contingent is required to maintain a paper copy of each participant's BSA Annual Health and Medical Record Form with the contingent leader during the conference and while traveling to and from the NOAC. Contingent leaders may be asked to provide a copy of their youth and adult participant's medical forms to the NOAC medical staff during registration and check-in of the lodge contingent. (The BSA Health and Safety Committee does not recommend placing these forms on a jump drive for travel.) Copies surrendered at registration will not be returned.

Immunizations

Immunization requirements are based on recommendations of the U.S. Public Health Service. Youth and adults must provide proof of immunization for tetanus within ten (10) years (since 2005). In addition, youth participants must provide verification of the following immunizations since birth:

- Diphtheria and pertussis.
- Measles, mumps, and rubella (MMR).
- Trivalent oral polio vaccine (TOPV) -- four doses recommended.

Exception to Immunization

If there is a reason why anyone is not able to comply with the vaccination requirements, the BSA Immunization Exemption Form must be submitted with the Annual Health and Medical Record. This form can be found within the electronic submission process and will appear if the applicant selects "Exemption" as an option, while completing the electronic form.

Special Situations/Special Needs

Many of the activities at NOAC are strenuous and could result in the need for special medical support or consideration. Therefore, it is necessary for the contingent leader and conference staff to be aware of participants who may require special considerations.

Every effort will be made in advance to provide resources and accommodations for Scouts and

Scouters with disabilities of any kind. **Facilities for disabled participants are limited and require advance arrangements.** Please make sure to list any special needs on the individual's registration form. **The NOAC committee cannot guarantee that last-minute arrangements for special needs can be accomplished.**

Special dietary needs are a common concern when attending any large function. The Dietary Staff at Michigan State University are very familiar with most special dietary needs. Whether they are for religious, medical or personal needs, they are able to accommodate most people.

Medical waivers will not be used for the 2015 NOAC.

Scuba

If a participant is planning to take part in the scuba activities at the 2015 NOAC, they will not need to complete the Scuba/PADI section of the BSA Annual Health and Medical Record.

Questions and Further Information

For any questions regarding these requirements or other medical issues or concerns, please contact the NOAC Medical Staff at NOACHEALTH@oa-bsa.org

LEADERSHIP POLICY FOR ALL ORDER OF THE ARROW TRIPS AND OUTINGS

It is the policy of the Boy Scouts of America that trips and outings may never be led by only one adult. **Two registered adult leaders or one registered adult leader and a parent of a participant, one of whom must be twenty-one (21) years of age or older, are required for all trips and outings.**

It is the responsibility of the council/lodge to ensure that sufficient qualified adult leadership is provided for all local, section, region, and national Order of the Arrow outings, conclaves, training events, and national events.

The interpretation of "adult" leadership and "adult" membership, as opposed to youth membership, in the Order of the Arrow continues to be one determined by age, not BSA registration. Although the Boy Scouts of America recognizes all individuals 18-years of age and older as adult members of the BSA, an individual under

the age of twenty-one (21) holds youth membership, while an individual who is twenty-one (21) years of age or older holds adult membership in the Order of the Arrow.

Although they hold youth membership in the Order of the Arrow, a member of the OA between the age of 18 and 21, who is registered as an assistant Scoutmaster or Venturer, may fulfill the leadership requirements as one of the adult leaders for an Order of the Arrow trip or outing.

Contingents that do not meet the minimum requirement of having two adult leaders, as set forth by the Boy Scouts of America, will not be authorized to participate in the conference.

Adult female leaders will be provided housing separate from the males in their contingent.

REGISTERED PARTICIPANTS ONLY

Only those persons officially registered with a lodge contingent or serving as approved NOAC staff will be sanctioned to participate in the national conference.

INSURANCE

Accident and sickness insurance is provided to all those attending the 2015 NOAC. The cost of this insurance is included as part of the NOAC fee.

Coverage for registered members of the BSA will be effective during travel from their homes to the NOAC site, from the NOAC site back home, and during their stay at the conference. The Maximum Benefit period is 52-weeks from the date of the covered accident. Health Special Risk must have the notice of claim within 90-days after any loss covered by the policy.

Excess Insurance Provision

The plan is an Excess Insurance Plan, meaning that the plan will pay all those eligible expenses incurred from a covered accident or sickness not paid by any other collectable insurance or pre-paid health plan in-force for you or a dependent child(ren). If no other collectable insurance or pre-paid health plan are in effect at the time of the loss, this plan will pay all eligible covered expenses up to the plan limits. There is no deductible under this plan. Also, coverage under this plan does not provide duplicate benefits when an

insured member is also insured under another Boy Scout or Learning for Life plan for a national or regional sponsored camp or special event. This provision applies to all benefits offered under these plans, including Accidental Death and Dismemberment.

Accident Medical Expense Benefits

The policy will pay benefits for covered expenses that result directly from a covered accident. The benefits are only payable for usual and customary charges and medically necessary covered expenses. Covered expenses will be paid only if charges incurred within 60-days after the date of the accident. Maximum benefit period is 52-weeks from the date of covered accident.

Total Maximum Benefits: \$15,000

Sickness Medical Expense Benefits

The policy will pay covered expenses for 52-weeks from the first date of treatment of a covered illness.

Benefit Maximum: \$7,500

Benefits for Accidental Death, Dismemberment, Heart Failure, Loss of Sight and Paralysis

When injuries to the insured result in death or dismemberment within one year from the date of the covered accident, and from loss which is independent of sickness and all other causes, the plan will pay as follows: In the event of multiple losses or death resulting from any one covered accident, only one benefit is payable... the larger amount applicable.

Covered Loss: \$2,500 up to \$20,000

Accident Death Benefit: \$10,000

ADDITIONAL BENEFITS:

Dental Treatment

This benefit shall be in addition to any other benefits payable under the terms of this plan. Pays for dental injuries, up to a total of \$5,000 for repair, treatment and/or replacement of sound, natural teeth. If within the 52-week period following the date of the accident, the insured's attending dentist certifies that dental treatment and/or replacement must be deferred beyond such 52-week period, the benefits will pay the estimated cost of such treatment; however, benefits will not exceed a total of \$5,000.

Benefit Maximum: \$5,000

Ambulance Expense Benefit

The policy pays ambulance expense for ground transportation from the emergency site to the hospital. The benefit includes air ambulance when, in the judgment of a duly authorized medical authority or senior representative of a camp or activity, such service is required to facilitate treatment of injuries and no other ambulance service is available. Ambulance benefits will be paid in addition to any other benefit payable under the policy.

Benefit Maximum: \$6,000

Return Transportation Expense Benefit

Transportation expenses incurred, as a result of a covered accident, the patient's medical provider requires the injured party to return home from a covered activity. This benefit includes the cost of one person to accompany the injured party on the trip. In the event of a covered death, the policy will pay expenses incurred for an immediate family member to accompany the body.

Benefits will not be paid unless the administrators of the policy authorize in writing or by an authorized electronic or telephonic means all expenses in advance.

Benefit Maximum: \$1,500

Post-Traumatic Stress Disorder

This benefit will pay \$100 per counseling session for up to five sessions, if the covered person suffers a diagnosed PTSD resulting directly and independently of all other causes from a covered accident. The benefit period is for 104- weeks from the date of the accident.

Crisis Management Benefit

This benefit will pay \$100 per counseling session for up to five sessions, if a covered person suffers a covered loss as the result of a felonious assault or from another person's use of a gun or knife to commit an act of violence, if the accident occurs while engaged in a covered activity. The benefit period is for 52-weeks.

Specified Injury Expense Benefit

The policy pays covered expenses incurred for treatment of a) loss of sight in both eyes; b) dismemberment of any extremity; c) paralysis; d) irreversible coma; e) entire loss of speech; or f) loss of hearing in both ears.

Benefit Maximum: \$35,000

EXCLUSIONS

The policy does not cover:

- (a) the cost of medical or surgical treatment or nursing service by a person employed or retained by the Boy Scouts of America High Adventure Base, or by any immediate family or member of the insured member's household;
- (b) any loss caused by suicide or attempted suicide;
- (c) any loss caused by intentionally self-inflicted injuries;
- (d) eyeglasses, contact lenses, hearing aids, examinations or prescriptions for them, or repair or replacement thereof;
- (e) loss caused by war or any act of war, whether declared or not;
- (f) dental treatment or dental x-rays, except when required as the result of injuries to sound, natural teeth;
- (g) Injury or sickness paid or payable by Workers' Compensation, Employer's Liability Laws or similar occupational benefits.

EMERGENCY PROCEDURES ENROUTE

In case of serious injury or illness enroute to or from the 2015 National OA Conference:

DO THESE THINGS IMMEDIATELY:

1. Take care of injured or sick person(s).
2. Make sure all other personnel are safe.
3. If necessary, get local emergency help.
 - a. Dial "0" or "911."
 - b. Inform local law enforcement officers in the event of an accident.

After taking these steps, gather the information indicated in steps 4 and 5. (Before you leave home, make sure you have emergency phone numbers for all your contingent members.)

4. Notify your local BSA council by telephone. (The council should notify the parents or spouse of the injured participant as soon as possible.)

Daytime office number:

()

Emergency night or weekend:

()

Alternative night or weekend:

()

5. Be prepared to provide the following information:

- a. Contingent housing location:
- b. Your name and leadership position:
- c. Location of accident (nearest town, highway, etc.)
- d. Hospital name and location:
- e. Name(s) of those ill or injured:
- f. Nature of illness or injuries:
- g. Action taken -- location of ill or injured and current condition.
- h. Name of physician and telephone number:
- i. Telephone number where a responsible leader in your group can be reached:
- j. Local law enforcement officers involved and the name of the officer in charge:

Responses to News Queries

Most accidents immediately become public knowledge over police, fire, or emergency radio circuits, and you may receive inquiries from news reporters. Respond factually, truthfully, and promptly. Be as helpful as possible; stick to the facts. Avoid making accusations, claims, charges, or speculations on how the accident happened.

ARRIVAL AND DEPARTURE PROCEDURES

Pre-Conference

- Contingent leaders have the opportunity, through the registration system, to request roommate pairings for their contingent members. NOAC Housing staff will do their best to accommodate roommate requests and house the contingent in close proximity. Roommate requests need to be entered into the NOAC Registration system by May 31, 2015.

- If a member of your contingent has a special housing request(s) due to mobility limitations, or other factors, please enter all requests into the NOAC Registration system. Please be very specific about the housing requirements, so that correct accommodations can be provided. Special housing requests need to be entered into the NOAC Registration system by May 31, 2015.
- The **NOAC Code of Conduct** (page 20) will need to be reviewed by all members of the contingent prior to NOAC, and it will be accessible through the NOAC Registration system.
- Contingents will be notified 7-days prior to arrival as to which residence hall they've been assigned. They will also receive detailed directions and instructions on where to go and disembark on the MSU campus.

Check-In

If you have attended National OA Conferences in the past, you may recall that Check-in Day started at a centralized place, generally a large arena on campus. This year, you will go directly to your assigned resident hall. That is your first stop! In fact, whether you are traveling by car or bus, you will pull up to your residence hall curbside to unload your gear. If you are arriving by plane, the airport shuttle bus will take you to your assigned residence hall. Prior to the conference, we will provide details on where your Lodge will be staying on campus, along with directions of how to get there.

Following a quick medical check (contingent leader should have a copy of each participant's medical form), you will be at your home for the week. The goal is to get you and your contingent into your rooms within a few minutes of arriving at NOAC. To help facilitate this process, your Housing staff will be located in each residence hall on Check-in Day and throughout the conference.

Once you are in your rooms, and your gear is stowed, you will immediately depart to an orientation that will kick-off your NOAC experience. The residence hall where you will be living is part of a neighborhood at

Michigan State University. There are five neighborhoods at MSU and each will have an orientation session and other activities to welcome

your lodge to the conference. (These orientations and activities are near your living quarters.)

In order to make this process smooth and quick, there are some things you can do in advance of the conference. The key is to have your registration information complete and accurate prior to your departure from home. The following is a brief checklist:

- **Each participant attending from your Lodge should be entered in the NOAC Registration database, ensuring that the roster in the system matches the Arrowmen you will actually bring to the conference.**
- **Medical forms need to be completed, uploaded and approved.**
- **Roommate assignments should be completed in the Registration System by the assigned deadline.**
- **Training classes and activities for each Arrowman should be selected and inputted into the Registration System (by individual Arrowman where applicable)**
- **Youth Protection Training must be completed for all Arrowmen 18 years and older.**

On Check-in Day, each neighborhood will have a station consisting of a registration team, training resources, and representatives from various conference committees to answer questions you may have about NOAC. (Details on the location for your neighborhood will be provided once your contingent arrives on campus.)

Departure

1. All linens, including pillows, blankets, and bed pads, are to be stripped from beds. All items collected are to be brought to the collection bins in the elevator lobbies of the residence hall.
2. All rooms are to be inspected, certified clean by the lodge contingent leadership. **(All items brought into the room by a NOAC participant must be removed upon departing.)**
3. The contingent leader collects and turns in all room keys, conference cards, and other materials as instructed. **Conference staff members are responsible for turning in their room keys and other materials as instructed.**
4. Complete other check-out procedures as may be instructed.

All lodge contingents must depart on Saturday, August 8, 2015 by 10:00 a.m. Meals are "on your own" after breakfast on Saturday, August 8th.

KEEP THE UNIVERSITY GROUNDS CLEAN

One of the challenges in connection with any national event is maintenance of orderly and neat conditions in heavily used areas. The cooperation of all participants is requested to see that all trash is deposited in the containers provided. Constant leader vigilance in this regard will be helpful in preventing a major problem. Make it a practice and a tradition -- no one passes by trash -- pick it up and put it in the proper container. SCOUTS LEAVE AN AREA BETTER THAN THE WAY THEY FOUND IT!

POLICY ON SMOKING, ALCOHOL AND DRUGS

Whenever a member of the Boy Scouts of America appears before the public, especially in uniform, that member is literally on parade before the citizens of America. This is especially true of the thousands that will be traveling to the national conference, participate in the week's events, and then depart for home. All of us must make sure that the conduct of every single participant is above reproach. This places a great responsibility on each of us.

The national conference committee has instituted a NO-SMOKING policy for all NOAC participants on the Michigan State University campus.

The use of alcoholic beverages, non-prescribed drugs, or controlled substances will not be permitted at NOAC or on the MSU campus and will result in immediate dismissal from the conference.

CHILD ABUSE

As a contingent leader, you will find yourself among thousands of youth and adults you may never see again. Unfortunately, as hard as we try to select only the very finest leaders, child molesters occasionally manage to slip through. As a leader, you are in a critical position to help safeguard our youth.

Abuse of children falls into many forms. There can be physical, mental, sexual, and even verbal abuse. It can happen within or outside the child's home. Abuse can come from a variety of sources within Scouting, including abuse by other youth, by adult leaders, and, even by parents themselves.

It is important to point out that most youth, most adult leaders, and most parents don't abuse the children with whom they come in contact. It is a rarity in Scouting.

Child abuse is difficult to spot, and therefore hard to do anything about. But, as a contingent leader or NOAC staff member, there are things you can do. It is your responsibility as a leader or staff member to believe any youth who tells you of sexual molestation or abuse of any kind. They will only tell you this if they feel that they have your trust, and you must respect that trust. They will have possibly come to you because no one else is willing to listen and believe them.

If the suspected abuse occurred during NOAC-related activities, you must report the case to the National OA Director. If abuse is reported to you, but it did not occur during conference-related activities, you still have an obligation to report it to the OA Director. Child abuse is against the law; and child abuse will not be tolerated in the Boy Scouts of America or the Order of the Arrow.

YOUTH PROTECTION TRAINING AND BACKGROUND CHECKS MANDATORY

Youth Protection Training

All Arrowmen 18-years of age and older attending the 2015 National Order of the Arrow Conference, must complete the Boy Scouts of America Youth Protection Training course. **It is mandatory that all registered BSA adult Scouters take the online Youth Protection Training, within the past two years prior to attending the NOAC.** The training must be completed and marked on their individual online registration form PRIOR to arriving on the Michigan State University campus. **The Youth Protection Training can be found at:** <http://www.scouting.org/Training/youthprotection.aspx>.

Background Checks

As part of our agreement to hold the 2015 National Order of the Arrow Conference on the Michigan State University campus, the Boy Scouts of America must certify that every individual 18-years of age and older has by August 3, 2015 completed a criminal background check, within the last 12-months.

As part of the NOAC individual registration process, participants and staff members 18-years of age and

older will be required to agree to this background check electronically, by checking the box on their registration form that they agree, to attend the 2015 NOAC. Personal information from each participant's and staff member's current BSA membership application will be used to complete the background check.

V. SPARK: 2015 National OA Conference Wide Game

Spark at the National Order of the Arrow Conference will play a key role in the overall guest experience. This program unifies the entire conference experience by creating a conference-wide game that encourages participation in the conference program and rewards involvement. In addition, Spark will provide conference planners and committees up-to-date information on staffing needs and attendee trends.

Spark turns the entire NOAC experience into a challenge and game. Guests and staff alike will be pushed to explore all that the conference has to offer as they earn virtual 'patches' and points for whatever they decide to do throughout the week.

Why Spark?

- Boost attendance at each committee's events, training sessions, and activities throughout the conference by making them part of the game. Points and 'patches' will be awarded to guests for their participation and involvement.
- Promote NOAC and the Order of the Arrow through social media integration and interaction between guests.
- Give each guest a tangible record of their personal NOAC experience.
- Provide participation feedback data to conference planners as quickly as possible to allow changes to be made to staffing.
- Provide resources and material to each guest, so that they can take NOAC back to their Lodge and share it in an impactful way.

Touchpoints

Touchpoints will be placed at most of the major events, program areas, special celebrations, and some training sessions. When a guest taps their device on the Touchpoint, they 'check in' at the event and collect

EAST LANSING AND MSU CURFEW

After 10:00 p.m. nightly, East Lansing and Michigan State University enforce a curfew for youth 16-years and younger. (Youth under the age of 17 must be escorted by a guardian, on campus and in East Lansing, after 10:00 p.m.)

any resources that may be contained in the Touchpoint.

The Device

Everybody at NOAC will be wearing a device attached to their name badge, which serves as their key to participating in Spark. Tapping the device on a swipe point 'checks in' the guest, and records the person's participation or attendance. "High-fouring" two of the devices together exchanges basic contact info between the two guests and records that they met. The device is also a USB flash drive, so any time guests plug it into a computer back home, they will have their entire NOAC experience right there with them: info from all of the people they met; things they did; and electronic copies of all of the training materials and resources they picked up along the way.

App & Website

There will be a smartphone app that allows guests to see their achievements throughout the week and view general conference information and announcements. For those who do not have a smartphone, an online web portal will also provide the same features and allow access to all of this data from any computer. Both contain the guest's "Patch Collection," every 'check in' they have recorded, the profiles of everyone they met at conference, and the resources they collected along the way.

IMPORTANT:

1. Arrowmen will receive an email in July with information on finalizing their profile for "Spark". Please ensure all contingent members complete this step before arriving at the conference.
2. There will be a NOAC 2015 App available in the App Store and Google Play Store. Please have all contingent members with smartphones

download the app prior to arriving at the conference.

3. Please consider bringing a minimum of 2-3 laptops to the conference with your contingent, so that Arrowmen (especially those without smartphones) won't have to rely

upon university resources to check their progress in the game. This is not critical to participating in the game, but it will make things easier for your Arrowmen if they have this access through your contingent.

VI. GENERAL INFORMATION

TOUR AND ACTIVITY PLAN

An online Tour and Activity Plan of your contingent's trip to and from the 2015 NOAC should be reviewed by the council prior to departure. This excellent guide and checklist for organization and administration of your travel and tour can be found at Scouting.org under FORMS.

VEHICLE INSURANCE

All vehicles used for Scouting programs must be covered by a liability insurance policy. The amount of this coverage must meet or exceed the insurance requirement of the state in which the vehicle is licensed. It is recommended, however, that coverage limits are at least \$100,000 combined single limit. Any vehicle designated to carry ten (10) passengers is required to have liability limits of \$500,000. In the case of rented vehicles, the requirement of coverage limits can be met by combining the limits of personal coverage carried by the driver with coverage carried by the owner of the rented vehicle.

VEHICLE DRIVERS

All drivers must have a current valid driver's license and be at least 18-years of age. A driver, 16-years of age may drive provided the following qualifications are met: (1) Six months' driving experience as a licensed driver (time on a learner's permit or equivalent is not to be counted); (2) no record of accidents or moving violations; (3) parental permission has been granted to contingent leader, driver, and riders; (4) and under the leadership of an adult, 21-years of age or older.

Driving is limited to a maximum of ten hours per day and must be interrupted by frequent rest, food, and recreation stops. If there is only one driver, the driving time should be reduced and stops made more frequently.

Seat belts must be provided in any vehicle used, and they must be worn by all passengers and the driver. Exception: A school or commercial bus. If trucks are used, passengers will ride only in the cab.

TRAVEL RESPONSIBILITIES

The contingent leader has overall responsibility for the contingent and is the one who determines policy. He may have an assistant in charge of physical arrangements who is also responsible for: coordinating funds, determining start times, mileage to be covered and travel time requirements, and arranging for first aid needs, meals, etc.

In handling funds, do not use personal checks because of the difficulty encountered in cashing them. Along with prepaid credit and/or debit cards, keep only a small amount of cash with your contingent when traveling. When you plan to stop at a restaurant enroute, it would be best to make advance reservations. An assistant leader could also be responsible for gathering general information about any side trips.

IN CASE OF EMERGENCY

Read "Emergency Procedures Enroute" in the administration section of this guide for appropriate action to be taken in case medical treatment or hospitalization is needed, including notification of parents, the local council, and the National BSA Council, through the contingent leader.

MSU EMERGENCY PHONE NUMBER

The emergency phone number (August 3 - 8, 2015) for parents/guardians to reach you while you are at Michigan State University:

517-355-1855

(Campus Operations/24 hours per day)

This number is to be used for emergencies ONLY! Anyone that may have to use the emergency phone number should be ready to give their name, lodge

name, and council headquarters city for rapid identification.

IF SEPARATED FROM THE CONTINGENT

Each member of the contingent must know and understand these rules:

- Stay with your buddy!
- Stay near the point of separation
- Phone your contingent at the next planned stop
- Request police or ranger assistance
- If necessary, check with the nearest local BSA council

EACH PERSON IS TO HAVE A COPY OF THE CONTINGENT ITINERARY.

Buddies and Credentials

- All youth should be paired with a buddy. This will prove advantageous in case of separation from the main group.
- Care must be exercised that every youth carries credentials identifying him as a member of the contingent along with his personal identification, which should include: name, address, parent's telephone number, religious faith, whom to notify in case of emergency, council, and headquarters city.
- Every youth must have pocket money for emergency use.

Receive Emergency Alerts from MSU Police

As part of its continuing effort to improve campus safety, Michigan State University police are unveiling a new portal for its alert and notification system that gives users, both on and off-campus, more flexibility in how they receive information during a threat or emergency.

Users automatically are set to receive emergency notifications, which are urgent messages asking

people to take specific actions. Users can also receive outreach messages, which are important notifications given during non-emergency situations. The portal, which can be found at <http://alert.msu.edu>, allows users to more easily review, add and modify existing contact information and/or manage the ways in which they receive emergency and outreach messages. Sign up with the NOAC specific drop down to receive alerts during the conference.

Social Media @ NOAC

NOAC participants can stay informed about the latest conference news through social media. We will have dedicated "NOAC" social media updates on Facebook, Twitter, YouTube, Instagram, and Snapchat. All participants and staff should follow these channels and check them regularly throughout NOAC for information and conference updates. In addition to communicating NOAC-specific updates, the NOAC social media accounts will enhance the overall NOAC experience through thought-provoking content, challenging games, and other fun surprises.

Participants with smartphones and mobile devices are encouraged to share their conference experiences on social media using the hashtag #NOAC2015. The NOAC social media team may share appropriate and relevant posts from our participants on the NOAC channels.

NOAC Website

NOAC participants are also encouraged to visit the NOAC website: event.oa-bsa.org for extensive information about NOAC including activities at the conference. Participants and staff will receive a monthly enews called The Ripple which will contain news about the conference.

SPECIAL NCOC/NLAG LEADERSHIP TRAINING OPPORTUNITY

As part of the online registration process, contingent leaders will register the lodge chief and one other youth, with lodge leadership potential, selected by the lodge chief to participate in the National Council of Chiefs (NCOC) on Tuesday afternoon of the conference (August 4). If the lodge chief will not be attending the conference, then the lodge chief should select another youth leader to attend the NCOC in his place, so the lodge has two youth representatives.

In addition, contingent leaders will register the lodge adviser and either the lodge staff adviser or a lodge associate adviser to participate in the National Lodge Adviser Gathering (NLAG) on Wednesday afternoon of the conference (August 5).

If one of these advisers will not be attending the conference, then the lodge adviser should select another adult to attend the NLAG, so the lodge has two adult representatives.

VII. SERVICES AND FACILITIES

POSTAL SERVICE

Inasmuch as the NOAC will last less than one week, participants should not encourage those back home to send mail to the university. However, should the need arise the NOAC mailing address is:

(Your Name)
(Council Headquarters City or Staff)
Attn: Laurin Gierman/NOAC
219 South Harrison Road
Room 63
East Lansing, MI 48824

ADVANCE SHIPMENTS OF EXHIBITS AND EQUIPMENT

Shipping, receiving, and warehousing will be managed through Michigan State University Services Logistics. Using MSU Logistics will allow your contingent and NOAC Administrative Services to track your shipments from the time materials arrive at MSU Logistics until the time they are delivered. Using the same tracking number provided to you by your shipping center. You can track your shipment using the University Services U-Track: <http://usd.msu.edu/common/tracking.html> (You will only be able to track your shipment through U-Track after it arrives at MSU Logistics and is entered into the tracking system.)

Please ship all of your NOAC goods to the address listed below so that Administrative Services can help you get your items in an efficient (and track-able) manner:

MSU Logistics
Boy Scouts – NOAC – (Insert Council Name Here)
Attention: (Lodge Contingent Leader’s Name)
166 Service Road
East Lansing, Michigan 48824

SHIP TO ARRIVE AFTER JULY 1, 2015
(Deliveries prior to July 1, 2015 will not be accepted.)

Once you arrive on campus, check with the conference Administrative Services office, in the Kellogg Center, for instructions on picking up your shipment.

NOAC AIRPORT TRANSPORTATION SHUTTLE

A chartered AIRPORT BUS SHUTTLE from Detroit Metro Airport (DTW) to Michigan State University for \$50

round trip will be available for NOAC participants on August 3rd (arrival day) and August 8th (departure day) ONLY.

If you’re flying and plan to use this service, you must make flight reservations between 7:00 a.m. and 4:00 p.m. Travel time between the Detroit airport and MSU is two and one-half hours. This shuttle service can be requested through the NOAC Registration system for flight(s) by group size.

Departures on Saturday, August 8th will commence at approximately 4:00 a.m. Airport check-in time, security screening, travel and load time on the campus, for your return trip, will be included in the total amount of time needed for your departure (minimum of 4-hours). Please plan your departures with these considerations.

Contingent leaders can reserve the airport shuttle service via the NOAC Registration system for flight(s) by group size after April 1st. Detailed information about the shuttle service will also be available on the NOAC Registration website in “PDF” format.

NOAC AMTRAK TRANSPORTATION SHUTTLE

Arrangements to transport contingents arriving at the Lansing Amtrak station via the train can also be requested on the NOAC Registration system. The station is conveniently located on the south side of the MSU campus. This is a courtesy service and will be provided at no charge. Contact information for your lodge leadership is required in case of delays.

NOAC CAMPUS SHUTTLE SERVICE

There will be a no-charge campus bus shuttle service for those in need that will circle the majority of the MSU campus starting on Monday, August 3rd. The service will be available Monday through Friday of the conference from 6:30 a.m. to 12:00 Midnight. A detailed route map will be in your participant guide. Some handicap accessible bus units will be available. **There will also be three handicap vans operating, which will be available by phone request.**

UNIVERSITY PARKING

Parking is extremely limited on Michigan State University’s campus, just as it is at many other college or university campuses. Vehicle storage lots will be available, with a shuttle service available from these

lots to the on-campus shuttle route. Please understand the parking limitations and respect the

posted parking instructions on campus. Campus parking enforcement will be monitoring lots, and parking tickets are the responsibility of the vehicle owner.

TRADING POST

The NOAC trading post will be available online (tradingpost.aa-bsa.org) and at the Brody Complex during the conference, offering a full complement of NOAC and Centennial merchandise. Conference participants are strongly encouraged to place a trading post order online by May 31, 2015, to ensure all mementos available can be purchased, thus reducing the risk of popular items not being available at the conference. Online orders may be placed during the conference; however, quantities may be limited.

The NOAC trading post will accept MasterCard, Visa, Discover and American Express credit/debit cards and cash.

TRADING POST ONLINE ORDER PICKUP OR SHIPPING

Trading post online orders to be picked up at NOAC must be done no later than 4:30 p.m. on Wednesday.

VIII. UNIFORMS AND EQUIPMENT

NOAC DRESS CODE

All conference participants and staff are to be in full Scout uniform at dinner and all evening shows.

Official Scout uniform:

- Scout shorts or trousers
- Scout shirt, short-sleeve casual
- Scout khaki web or leather belt
- Scout socks
- Scout visor cap or NOAC cap
- Order of the Arrow (Red Centennial Sash)

Activity Dress

For breakfast, lunch, training sessions, day time and evening activities and events, participants and staff may wear a NOAC, OA or Scout t-shirt or golf shirt with their Scout shorts or trousers during the conference.

The official Scout Uniform is appropriate to wear at any time during the conference.

August 5, 2015. Online orders scheduled for pickup and not picked up by August 5th will be shipped.

All online orders, scheduled for shipping, will be shipped from the NOAC site beginning Monday, August 3, 2015.

ROOM KEYS AND CONFERENCE CARDS

Each conference participant will be responsible for safeguarding his room key and conference card. Local Councils will be billed directly by the National Council for all lost keys and conference cards. It is the Local Council's responsibility to pay the bill to the National Council and to collect reimbursement from the contingent member who incurred the cost if they choose to do so.

LOST AND FOUND

Michigan State University will collect and maintain custody of lost articles left at the University by persons attending the conference, and we will make every effort to return the items to either the rightful owner or the BSA. If a participant or staff member loses an item while attending NOAC, they can check with Administrative Services in the Kellogg Center for their lost and found item(s).

Recommended Personal Equipment

Beach towel for all water activities (Towels are not to be taken from resident halls.)

Personal water bottle(s)

Medications

Emergency phone numbers (including work #s)

Toothbrush

Toothpaste

Deodorant

Underwear

Sun glasses

Sun screen

Shaving kit

Alarm clock

Small portable fan*

*The NOAC trading post will be selling box fans online, which will be distributed by Neighborhood to the contingents on check-in day. (The resident halls at MSU are not air conditioned.) **The university does not allow window or portable air conditioners of any kind!**

Bicycles

Michigan State University's campus is very bike friendly. If participants wish to bring bicycles to use during the conference, the bikes must be parked and locked at a bike rack when not in use. The bike must also be in good operating condition, or it will be impounded with fees assessed to retrieve it.

Helmets are mandatory on campus!

Towels and Bedding at MSU

The university will provide each participant with two sheets, pillow, pillow case, blanket, and a towel. Towels and bed linens may be exchanged at your residence hall Service Desk during your stay.

Required Contingent Equipment

- 1 – wooden/fabric lodge flap emblem for the opening show (See diagram pg. 19)
- 2 – contingent rosters:
 - 1 – for the contingent leader, with name, address and emergency contact phone number for each participant.
 - 1 – just in case!
- 2-3 - Laptops (recommended) so that Arrowmen, especially those without smartphones, won't have to rely upon university resources to check their progress in the conference wide-game.

REMEMBER! All participants must have a completed (signed) BSA Annual Health and Medical Record form (Parts A, B and C); and Contingent Leaders should have a copy of each participants medical form while traveling to and from the NOAC.

For MSU and East Lansing information, please visit:

www.msu.edu or www.lansing.org

Giant Lodge Flap

The Shows Committee would like all lodges to make a sturdy cardboard, plywood, or fiberboard flap (painted) to the dimensions below. This flap sign will be used in the opening show at the National Order of the Arrow Conference. One youth representative from each lodge will carry and display his lodge's sign in the opening show.

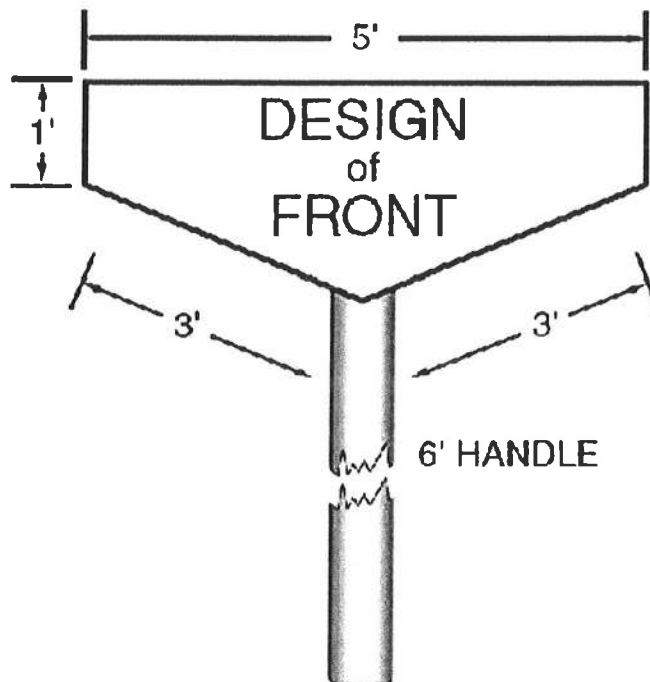

2015 NATIONAL OA CONFERENCE CODE OF CONDUCT

The general welfare of our group depends on the conduct of each individual; this ensures the success of NOAC and provides the maximum benefit to everyone. As an Arrowman, I understand this and support the reasonable demands of conduct expected of me.

I understand the lodge contingent leadership is responsible for supervision with respect to maintaining discipline and security; and for enforcing the NOAC Code of Conduct.

As a member of the Order of the Arrow at NOAC, I will:

1. Observe the Scout Oath, Scout Law and the Order of the Arrow Obligation.
2. Be in full Scout uniform at dinner and all evening shows. For all other meals, training sessions, activities and events, participants may wear a NOAC, OA or Scout t-shirt or golf shirt with their Scout shorts or trousers.
3. Attend all planned training and general sessions.
4. Confine patch trading to free periods and designated areas.
5. Be personally responsible for breakage, damage, or loss of property.
6. Observe quiet hours and lights out from midnight to 7:00 a.m.
7. Keep my room clean and orderly and dispose of trash in proper receptacles.
8. Not change my officially assigned room without permission from NOAC headquarters. The reason: emergency calls, for example, could not be delivered when room changes are unofficial.
9. Allow no unregistered person to occupy my room.
10. Wear suitable covering in the resident hall when going down the corridors. I will also wear suitable covering while swimming or participating in any conference program.
11. Observe all rules regarding the use of the pools and other athletic facilities.
12. Refrain from the purchase, possession, or consumption of alcoholic beverages or illicit drugs at the conference, as they are not permitted and will result in immediate dismissal from NOAC. This standard applies to all youth and adult participants.
13. Comply with federal, state and city laws, and university regulations, including those that prohibit the use of fireworks, firearms, and gambling. Infraction of these laws and regulations will be cause for immediate dismissal from NOAC.
14. Not sell items at the conference. I understand that the official trading post is the only source for sale/purchase of memorabilia and materials at NOAC.
15. Abide by the NOAC and MSU NO SMOKING policies at all times.
16. At all times, be the considerate guest of a considerate host university.